

Model # T46PERFPED-3SM

HARDWARE

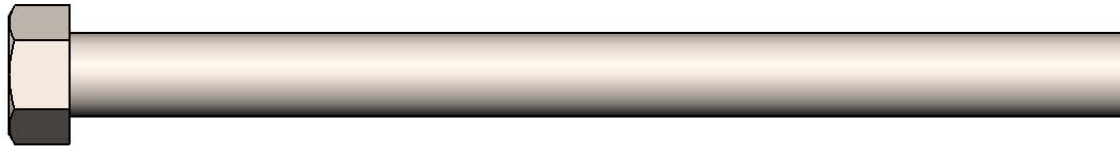

7/16" x 5-1/2"
Machine Bolt

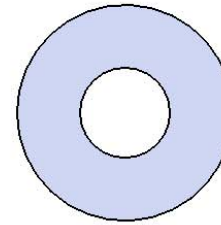

7/16" Washer

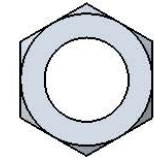

7/16" Hex Nut



5/16" x 1"
Machine Bolt

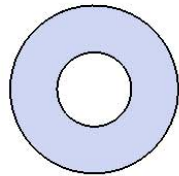

5/16" Washer

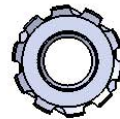

5/16" Kep Nut

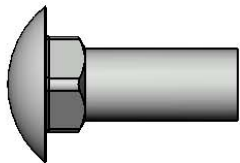

3/8" x 1"
Carriage Bolt

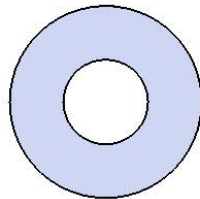

3/8" Washer

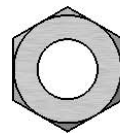

3/8" Hex Nut

TOOLS REQUIRED

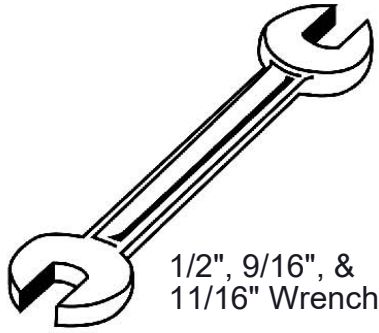

1/2", 9/16", &
11/16" Wrench

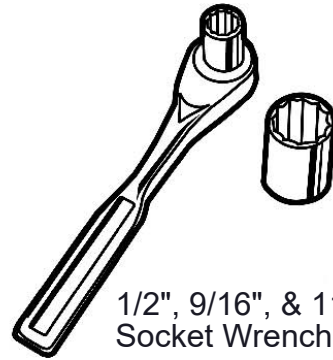

1/2", 9/16", & 11/16"
Socket Wrench

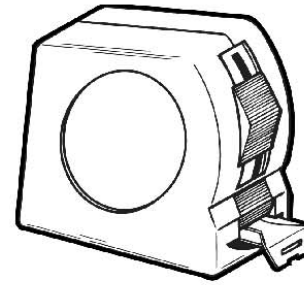

Tape Measure

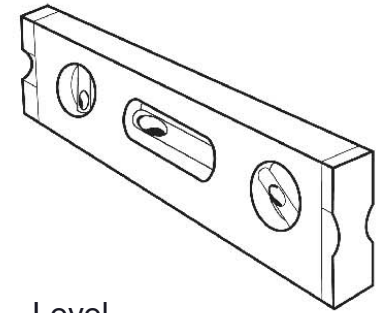

Level

PRODUCT SPECIFICATIONS

T46PERFPED-3SM 46" SQUARE SURFACE MOUNT TABLE WITH 3 SEATS

Top & Seats: Top and seats shall have a 1-1/2" radius edge, fabricated from a 14ga. plate. Holes are precision punched at 5/8" diameter to create the punched hole pattern. 7ga. x 1-1/2" flat bar center support and mounting bracket understructure. Top is additionally diagonally supported to the corner with 7ga. x 1-1/2" flat bar. Electrically MIG welded.

Coating: Oven fused functionalized polyethylene copolymer-based thermoplastic. Fluidized bed coating application with superior mechanical performance, impact resistance and UV-stability.

Frame: Main support column is 4"x4"x11 gauge pre-galvanized structural steel tubing. Arms are fabricated from 2-7/8" O.D. x 12 gauge pre-galvanized structural steel tubing welded to 1/4" precision punched plates for attachment to the main column and 2"x2"x3/16" structural steel angle for lateral seat support. Seat attachment points are 10 gauge precision punched tabs. Table top attachment structure is fabricated from 2"x2"x3/16" structural steel angle and top attachment points are 7 gauge x 1-1/2" steel flat bar. Surface mount plate is 16" x 16" x 1/2" thick. All electrically MIG welded.

Frame Coating: Electrostatic powder coated application oven cured.

Hardware: All stainless steel hardware fasteners.

Dimensions: Top is 46" square x 30" high. Seats are 12" wide x 36" long x 18" high. Outside to outside dimensions of 3 seat table is 61-1/4" x 71-3/4".

COMPONENTS

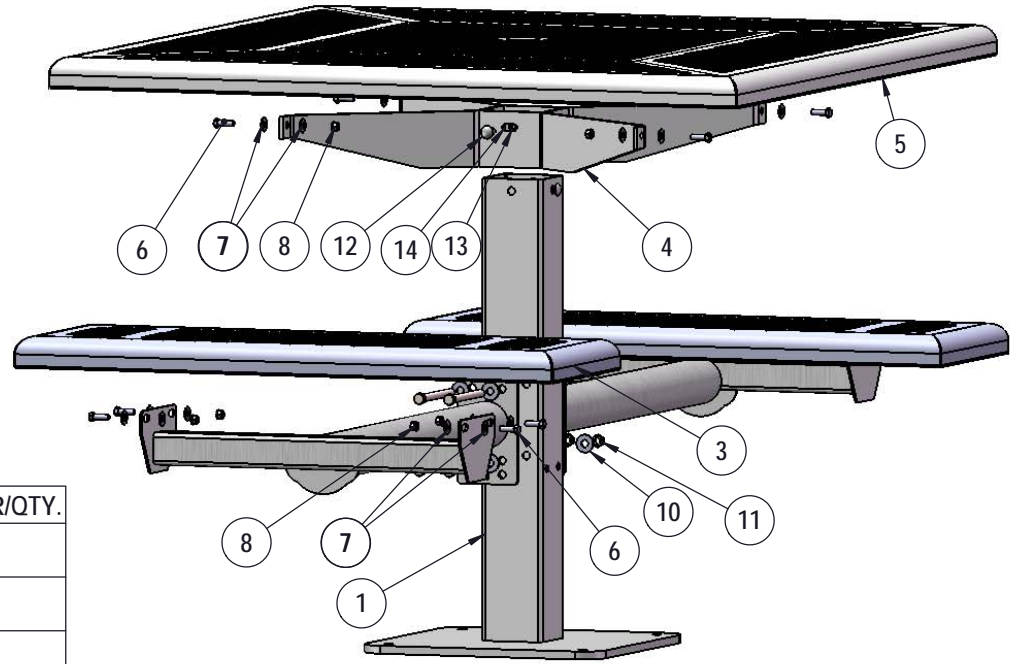

ITEM NO.	PartNo	DESCRIPTION	338SMH3-PR/QTY.
1	338SM	338 SM post asem	1
2	P-V338-ARM	338 vinyl arm	3
3	T-PR36-S	3' Punched Rolled Seat	3
4	P-01-04-0150	H Bracket	1
5	T-PR46-T	46" Square Punched Rolled Top	1
6	33-05-0029	5/16" x 1" Machine Bolt (SS)	16
7	33-02-0007	5/16" SS Washer	32
8	33-03-0012	5/16" Kep Nut (SS)	16
9	33-06-0050	7/16" x 5-1/2" Machine Bolt	8
10	33-02-0004	7/16" SS Washer	16
11	33-01-0006	7/16" Hex Nut (SS)	8
12	33-06-0042	3/8" x 1" Carriage Bolt (SS)	4
13	33-01-0018	3/8" Hex Nut (SS)	4
14	33-02-0008	3/8" Flat Washer (SS)	4

Recommended Surface Mount Hardware:
 3/8" x 3-1/2" Concrete Expansion Anchor Bolts
 (Not Included)

Superior[®]
 RECREATIONAL PRODUCTS
A PLAYCORE Company

STEP 1

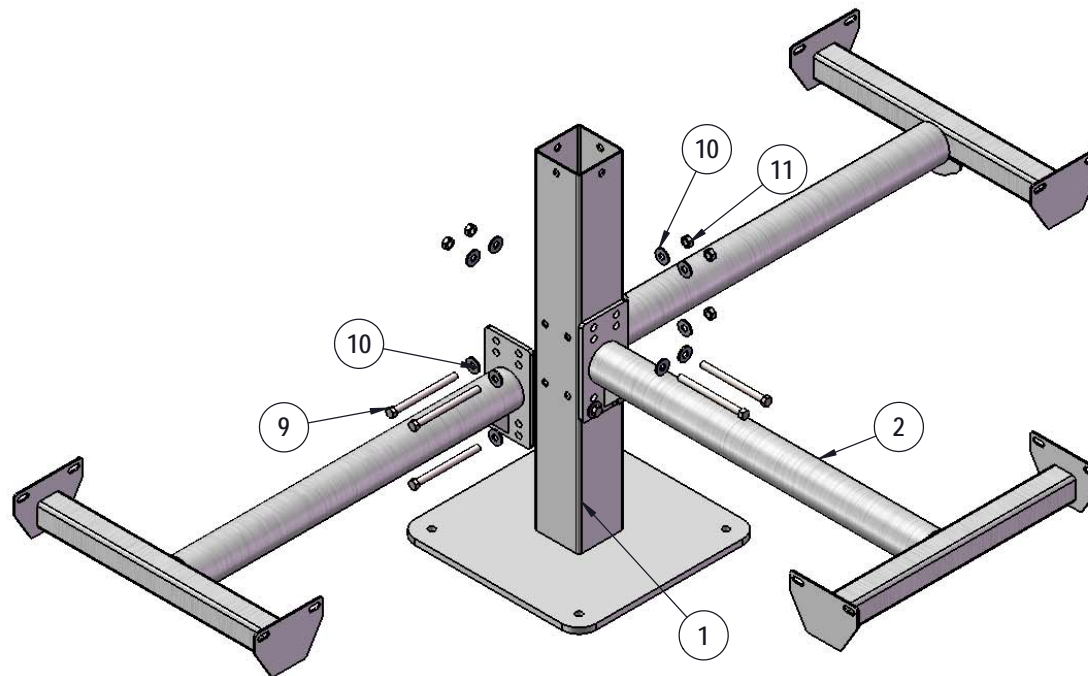

Attach the 338 Vinyl Arms the in 338 Post using specified hardware.

STEP 2

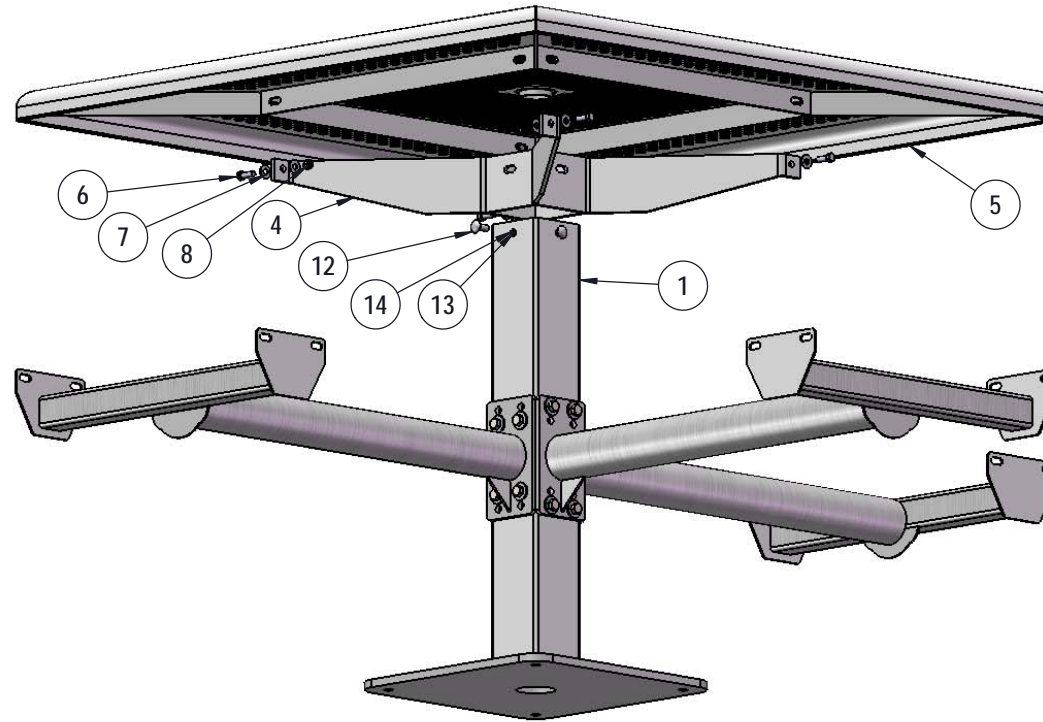

Attach the H-Bracket to the 338 Post using specified hardware.
Then Attach the 46" Square Top to the H-Bracket using specified hardware.

Superior[®]
RECREATIONAL PRODUCTS
A PLAYCORE Company

STEP 3

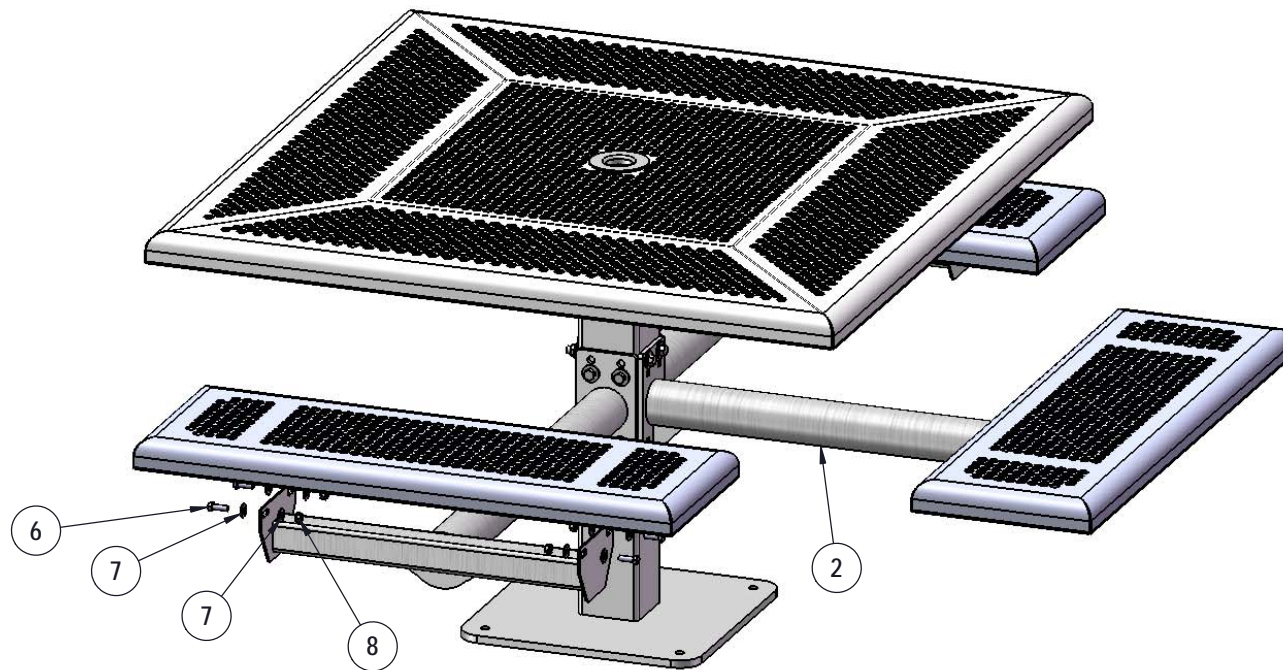

Attach the 3' Seats to the 338 Vinyl Arms using specified hardware.

OVERALL DIMENSIONS

